

Section 7 - Wiring Diagrams and Block Diagrams

Wiring Diagram 7.1 - C960 SCR 240 Vac	7-3
Block Diagram 7.2 - C960 SCR 240 Vac.....	7-4
Wiring Diagram 7.3 - C962, C964 SCR 120 Vac.....	7-5
Block Diagram 7.4 - C962, C964 SCR 120 Vac.....	7-6
Wiring Diagram 7.5 - C962, C964 SCR 240 Vac.....	7-7
Block Diagram 7.6 - C962, C964 SCR 240 Vac.....	7-8
Wiring Diagram 7.7 - C960 PWM 240 Vac	7-9
Block Diagram 7.8 - C960 PWM 240 Vac	7-10
Wiring Diagram 7.9 - C962, C964 PWM 120 Vac	7-11
Block Diagram 7.10 - C962, C964 PWM 120 Vac.....	7-12
Wiring Diagram 7.11 - C962, C964 PWM 240 Vac	7-13
Block Diagram 7.12 - C962, C964 PWM 240 Vac.....	7-14
Wiring Diagram 7.13 - C962i, C964i 120 Vac	7-15
Block Diagram 7.14 - C962i, C964i 120 Vac.....	7-16

Wiring Diagram 7.45 - C962i, C964i 240 Vac 7-17

Block Diagram 7.16 - C962i, C964i 240 Vac 7-18

Wiring Diagram 7.1 - C960 SCR 240 Vac

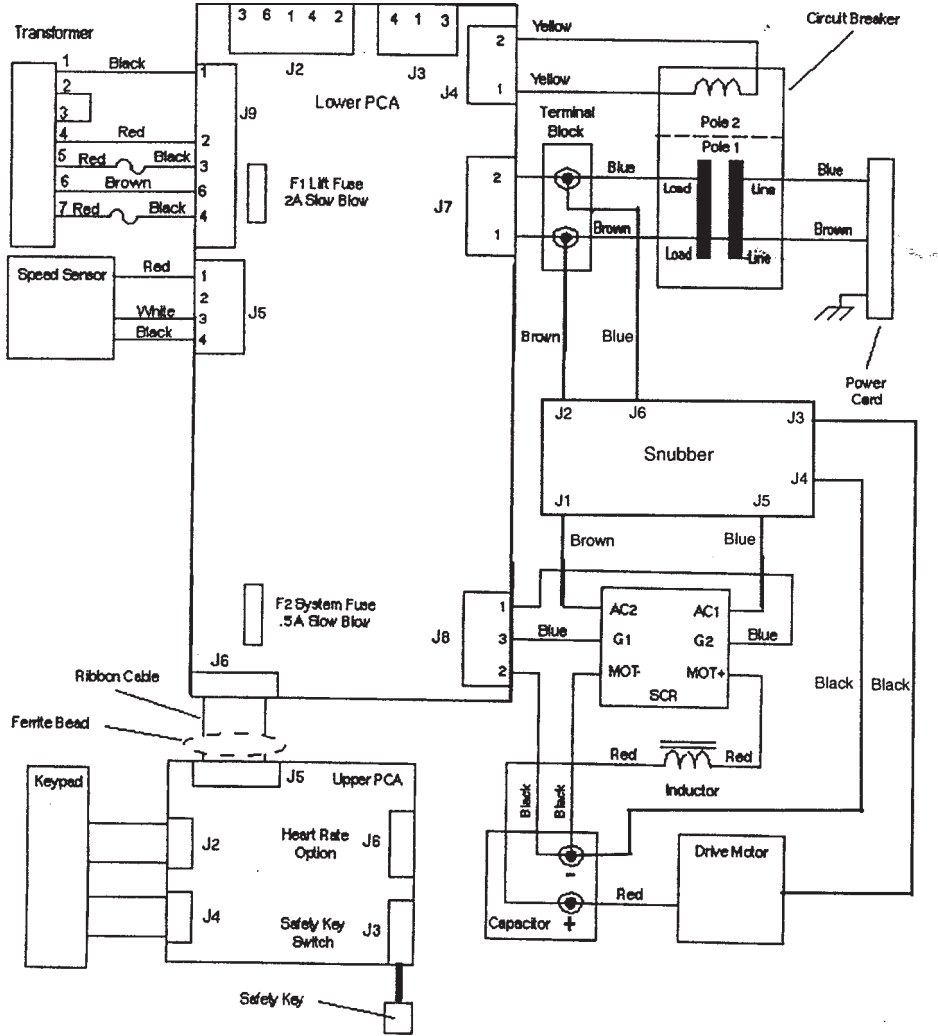

Block Diagram 7.2 - C960 SCR 240 Vac



C960-240 SCR Treadmill

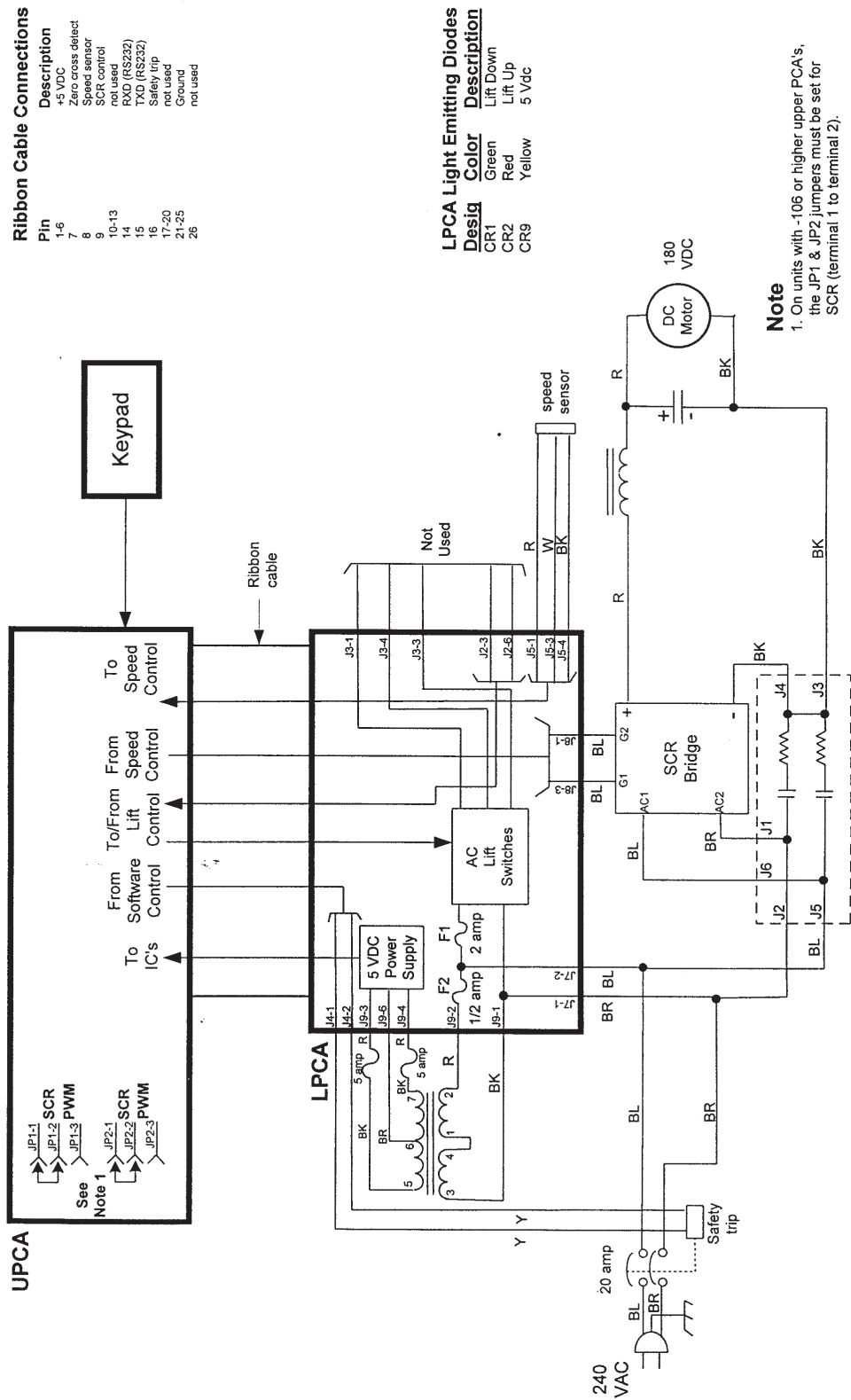

Ribbon Cable Connections

Pin	Description
1-6	+5 VDC
7	Zero cross detect
8	Speed sensor
9	SCR control
10-13	not used
14	PAD (RS232)
15	PAD (RS232)
16	Start/Up
17-20	not used
21-25	Ground
26	not used

LPCA Light Emitting Diodes

Design	Color	Description
CR1	Green	Lift Down
CR2	Red	Lift Up
CR9	Yellow	5 Vdc

Note
 1. On units with -106 or higher upper PCA's, the JP1 & JP2 jumpers must be set for SCR (terminal 1 to terminal 2).

Wiring Diagram 7.3 - C962, C964 SCR 120 Vac

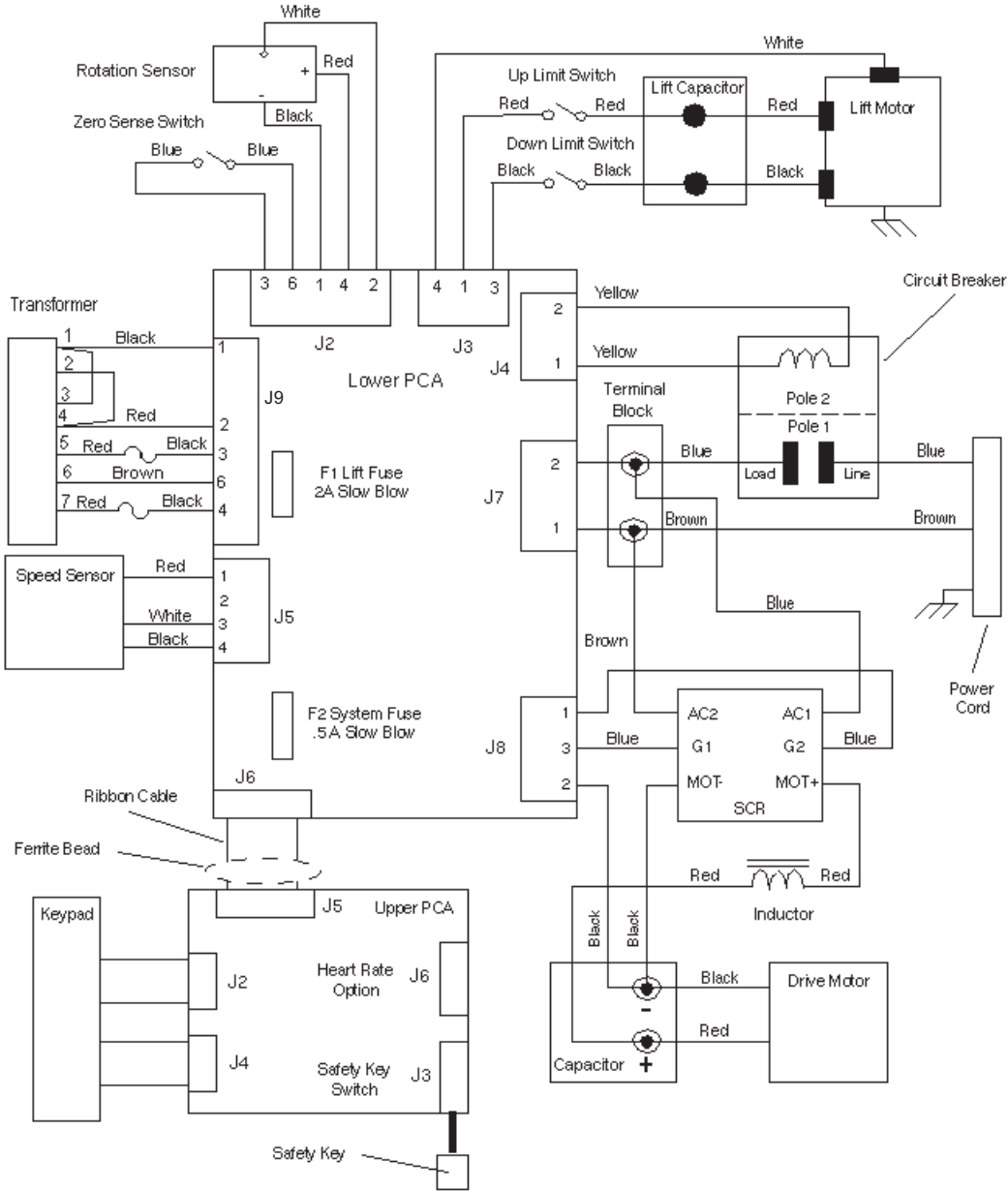

Block Diagram 7.4 - C962, C964 SCR 120 Vac



9.45-120 Treadmill (built prior to 5/1/96)

C944-120, C962-120, C964-120 SCR Treadmill

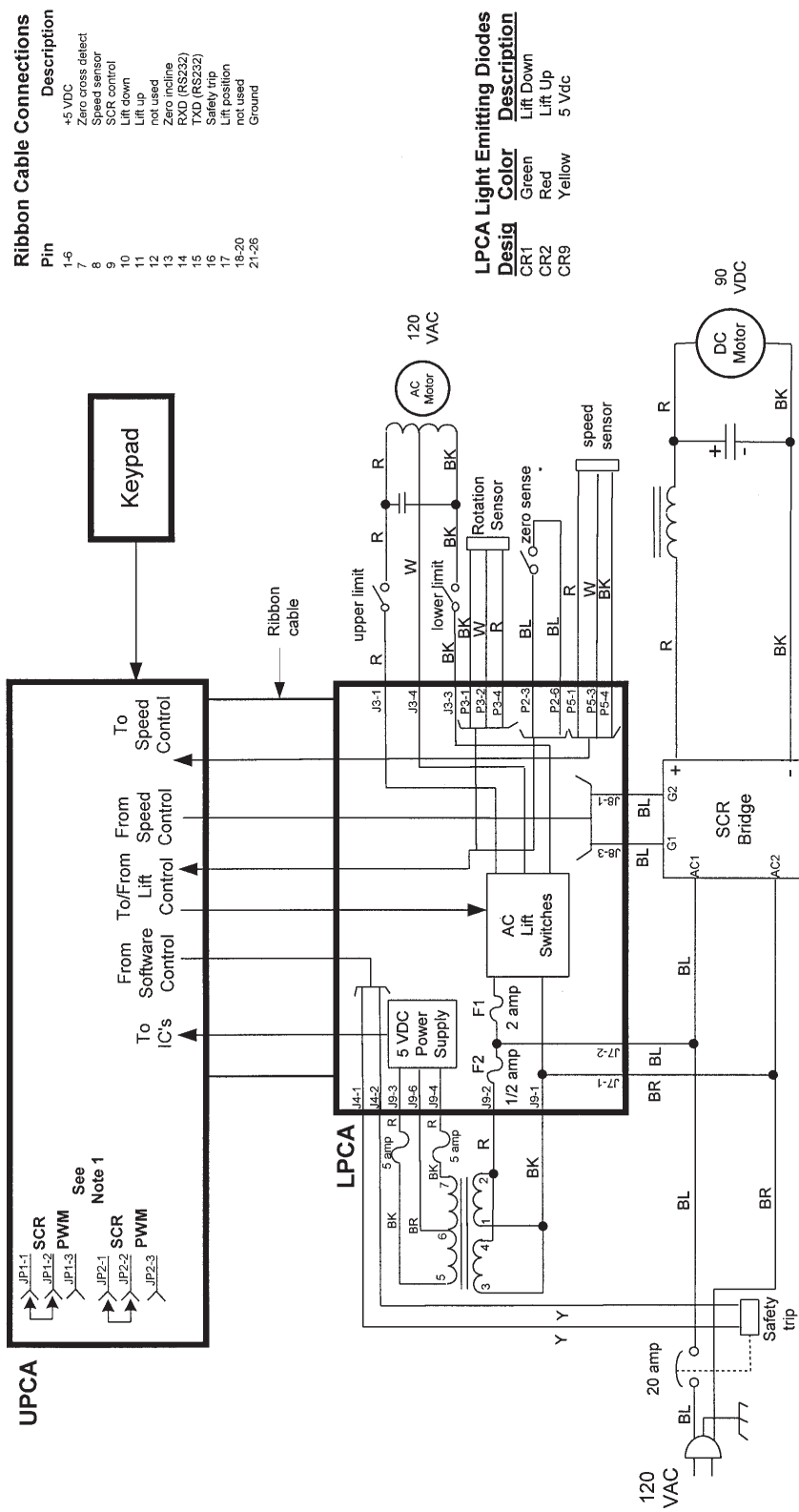

Ribbon Cable Connections

Pin	Description
1-6	+5 VDC
7	Zero cross detect
8	Speed sensor
9	SCR control
10	Lift down
11	Lift up
12	not used
13	Zero incline
14	RXD (RS232)
15	TXD (RS232)
16	Safety trip
17-20	Lift position not used
21-26	Ground

LPCA Light Emitting Diodes

Design	Color	Description
CR1	Green	Lift Down
CR2	Red	Lift Up
CR9	Yellow	5 Vdc

Note
 1. On C962's & C964's with -106 or higher upper PCAs, the JP1 & JP2 jumpers must be set for SCR (terminal 1 to terminal 2)

Wiring Diagram 7.5 - C962, C964 SCR 240 Vac

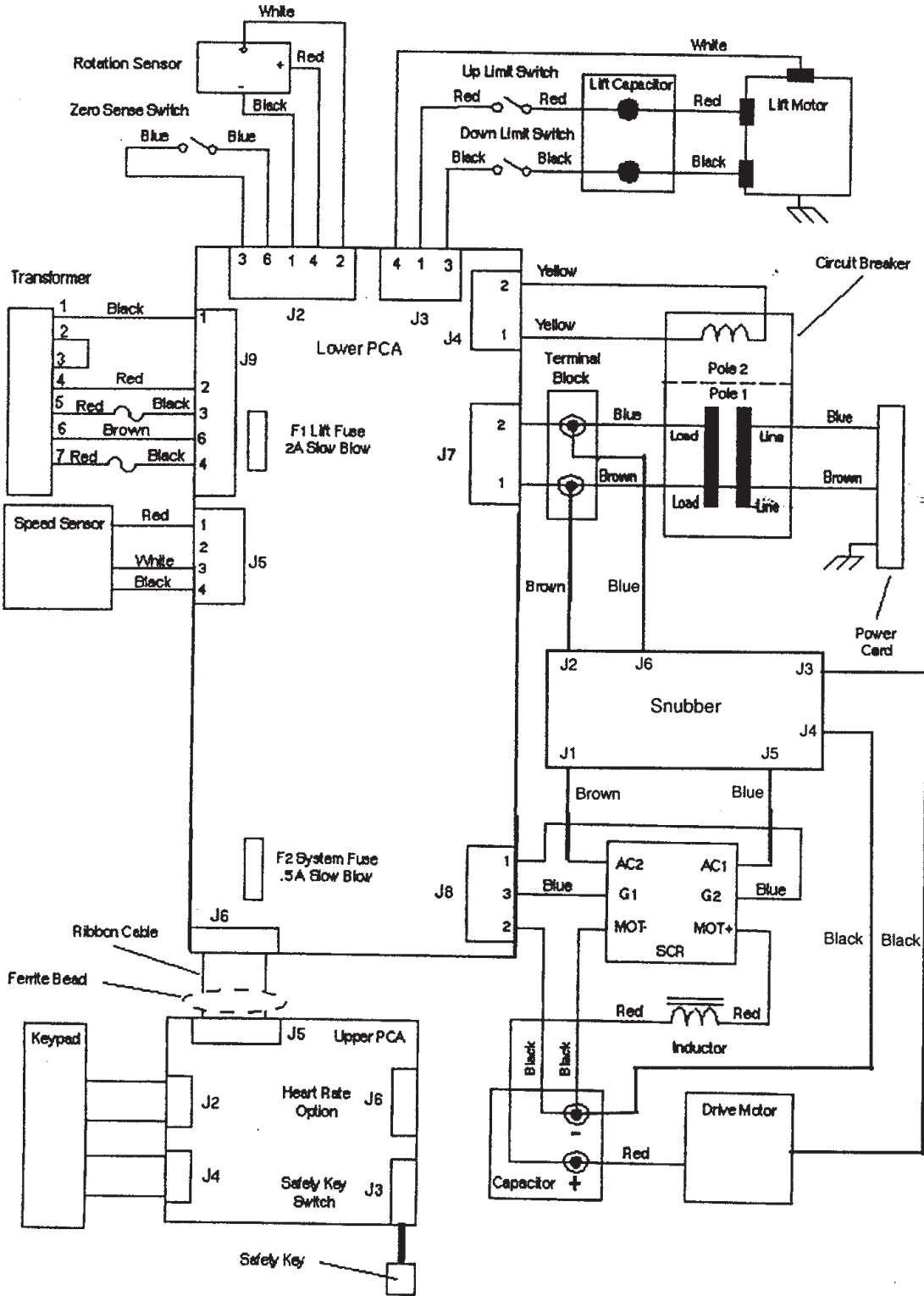

Block Diagram 7.6 - C962, C964 SCR 240 Vac



C944-240, C962-240, C964-240 SCR Treadmill

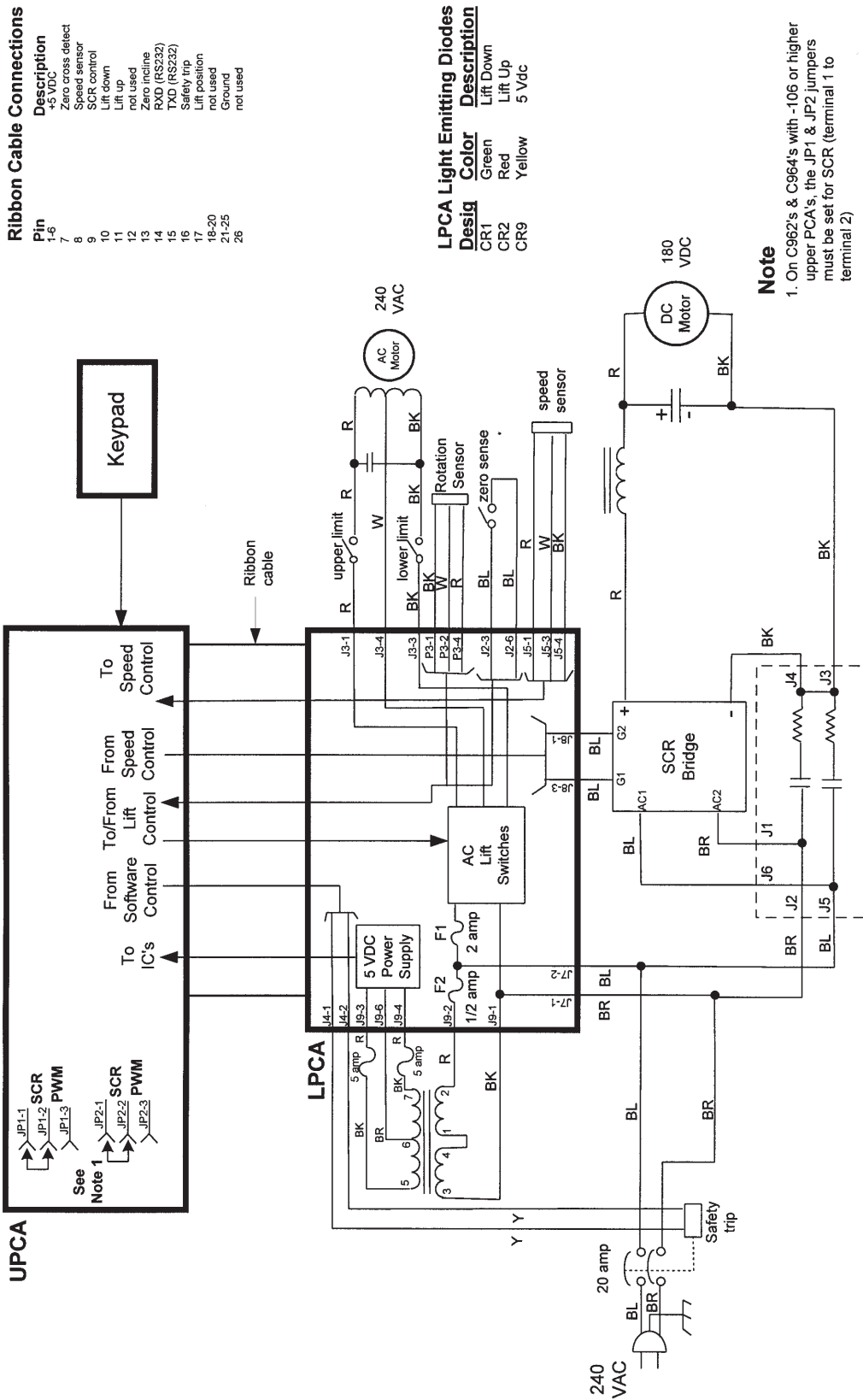

Ribbon Cable Connections

Pin	Description
1-6	+5 VDC
7	Zero cross detect
8	Speed sensor
9	SCR control
10	Lift down
11	Lift up
12	not used
13	Zero incline
14	RXD (RS232)
15	TXD (RS232)
16	Safety trip
17	Lift position
18-20	not used
21-25	Ground
26	not used

LPCA Light Emitting Diodes

Design	Color	Description
CR1	Green	Lift Down
CR2	Red	Lift Up
CR9	Yellow	5 Vdc

Note
 1. On C962's & C964's with -106 or higher upper PCA's, the JP1 & JP2 jumpers must be set for SCR (terminal 1 to terminal 2)

Wiring Diagram 7.7 - C960 PWM 240 Vac

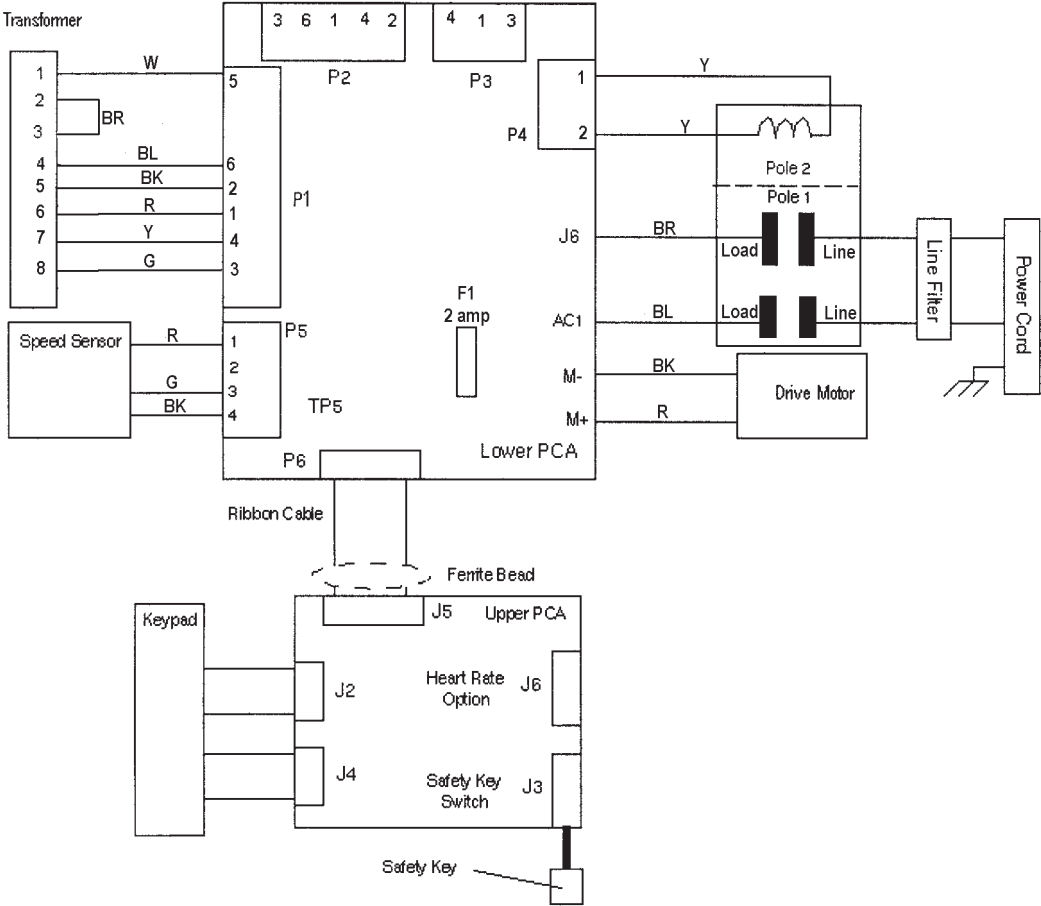

Block Diagram 7.8 - C960 PWM 240 Vac



C940/240, C960/240 PWM Treadmill

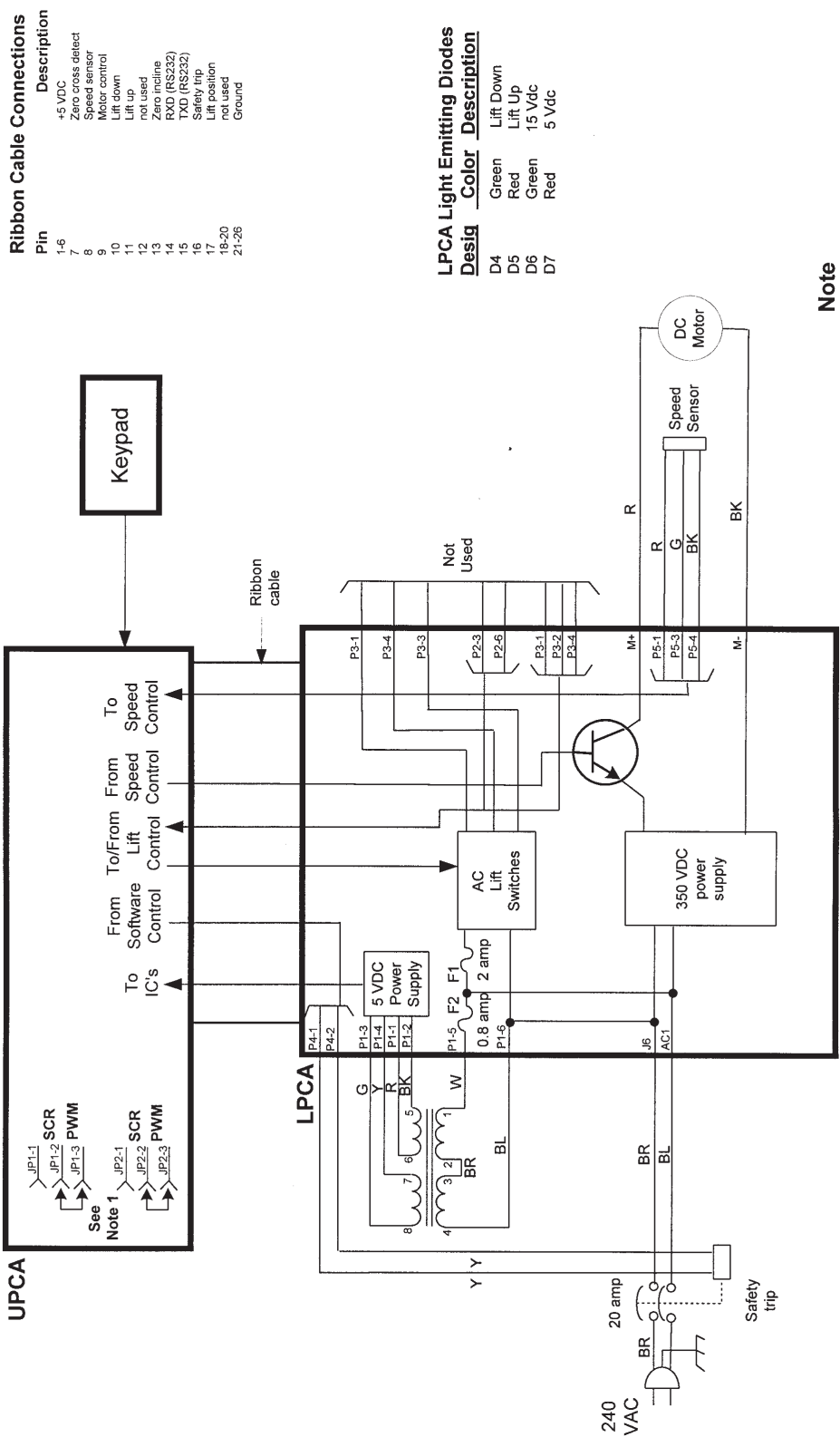

Ribbon Cable Connections

Pin	Description
1-6	+5 VDC
7	Zero cross detect
8	Speed sensor
9	Motor control
10	Lift down
11	Lift up
12	Zero speed
13	Zero incline
14	RXD (RS232)
15	TXD (RS232)
16	Safety trip
17	Lift position not used
18-20	not used
21-26	Ground

LPCA Light Emitting Diodes

Design	Color	Description
D4	Green	Lift Down
D5	Red	Lift Up
D6	Green	15 Vdc
D7	Red	5 Vdc

Note
 1. C960 upper PCA jumpers JP1 & JP2 must be set for PWM (terminal 2 to terminal 3)

Wiring Diagram 7.9 - C962, C964 PWM 120 Vac

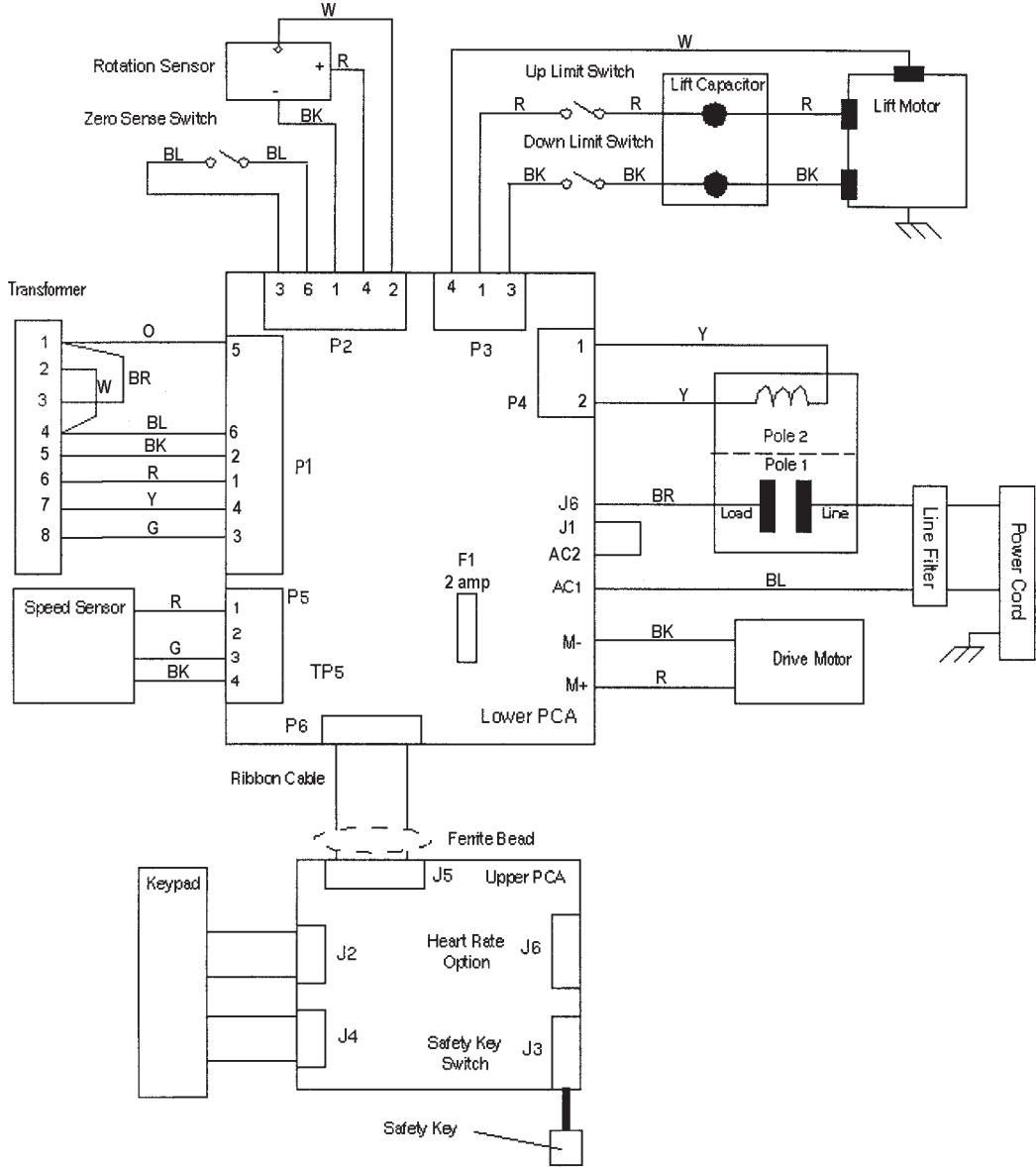

Block Diagram 7.10 - C962, C964 PWM 120 Vac



C944/120, C962/120, C964/120 PWM Treadmill

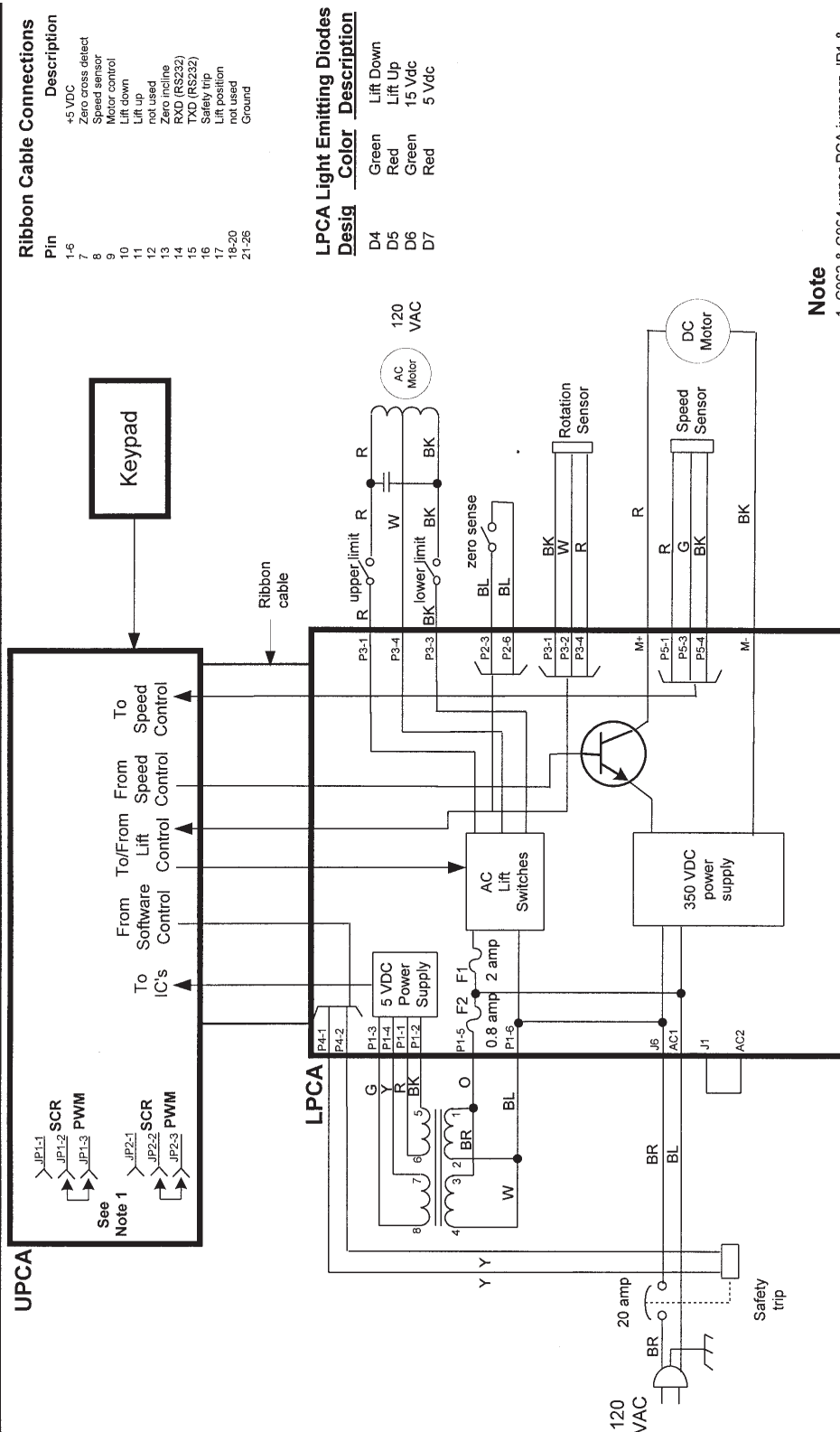

Pin	Description
1-6	+5 VDC
7	Zero cross detect
8	Speed sensor
9	Motor control
10	Lift down
11	Lift up
12	not used
13	Zero incline
14	RXD (RS232)
15	TXD (RS232)
16	Safety trip
18-20	Lift position
21-26	not used
	Ground

Design	Color	Description
D4	Green	Lift Down
D5	Red	Lift Up
D6	Green	15 Vdc
D7	Red	5 Vdc

Note

1. C962 & C964 upper PCA jumpers JP1 & JP2 must be set for PWM (terminal 2 to terminal 3)

Wiring Diagram 7.11 - C962, C964 PWM 240 Vac

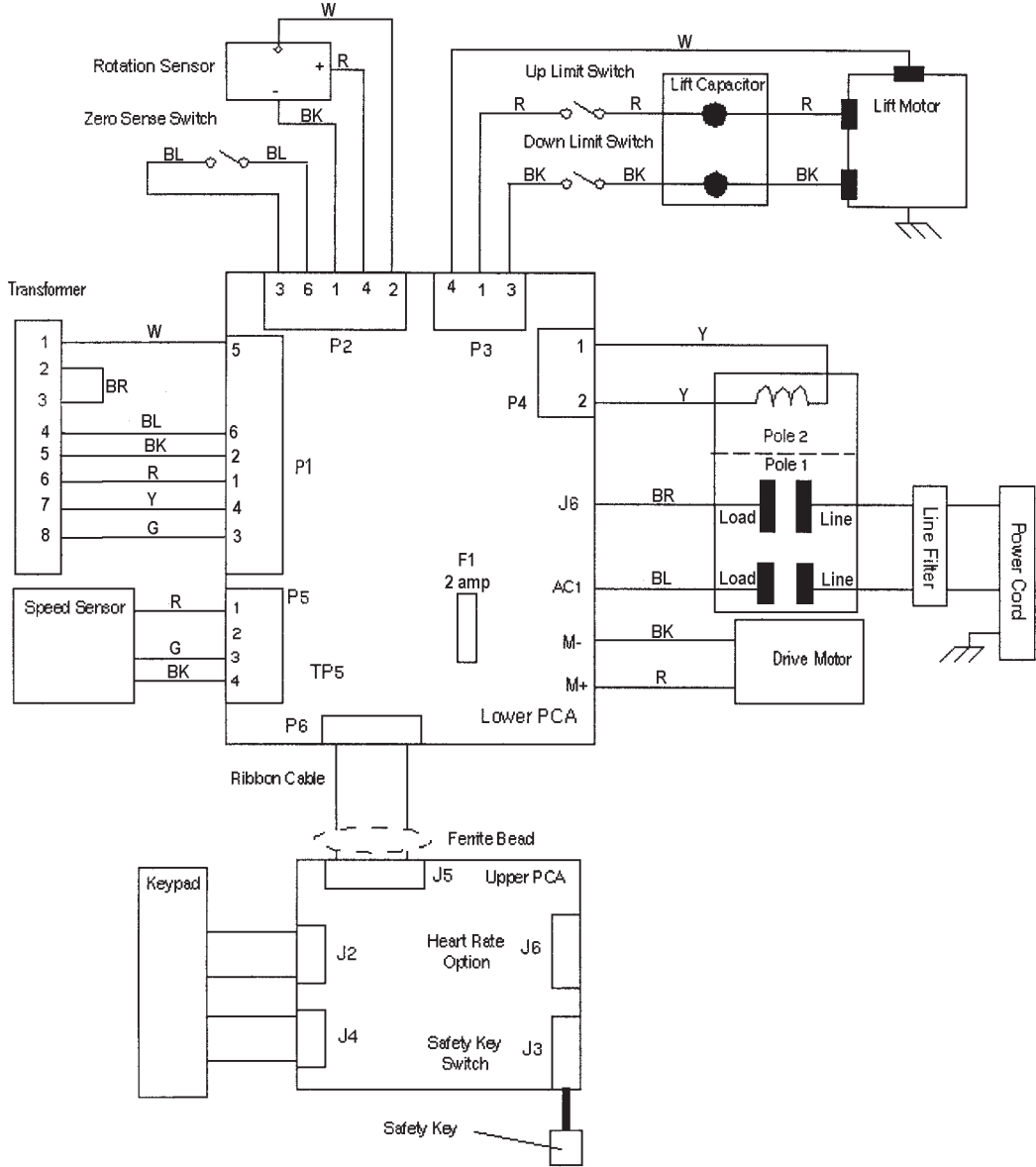

Block Diagram 7.12 - C962, C964 PWM 240 Vac

PRECOR
VSN

C944/240, C962/240, C964/240 PWM Treadmill

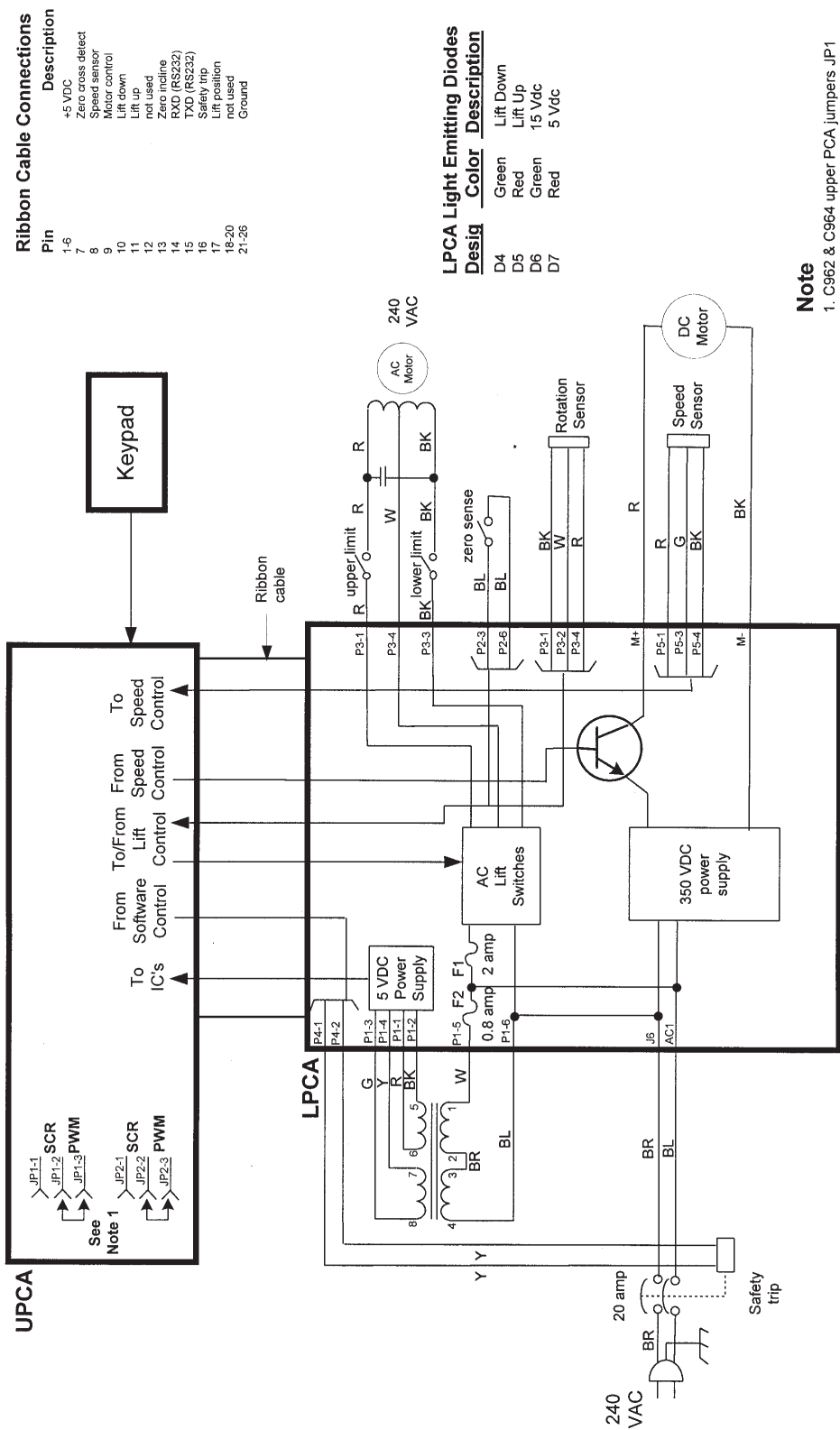

Ribbon Cable Connections

Pin	Description
1-6	+5 VDC
7	Zero sense detect
8	Speed sensor
9	Motor control
10	Lift down
11	Lift up
12	not used
13	Zero incline
14	RXD (RS232)
15	TXD (RS232)
16	Safety trip
17	Lift position
18-20	not used
21-26	Ground

LPCA Light Emitting Diodes

Desig	Color	Description
D4	Green	Lift Down
D5	Red	Lift Up
D6	Green	15 Vdc
D7	Red	5 Vdc

Note
1. C962 & C964 upper PCA jumpers JP1 & JP2 must be set for PWM (terminal 2 to terminal 3)

Wiring Diagram 7.13 - C962i, C964i 120 Vac

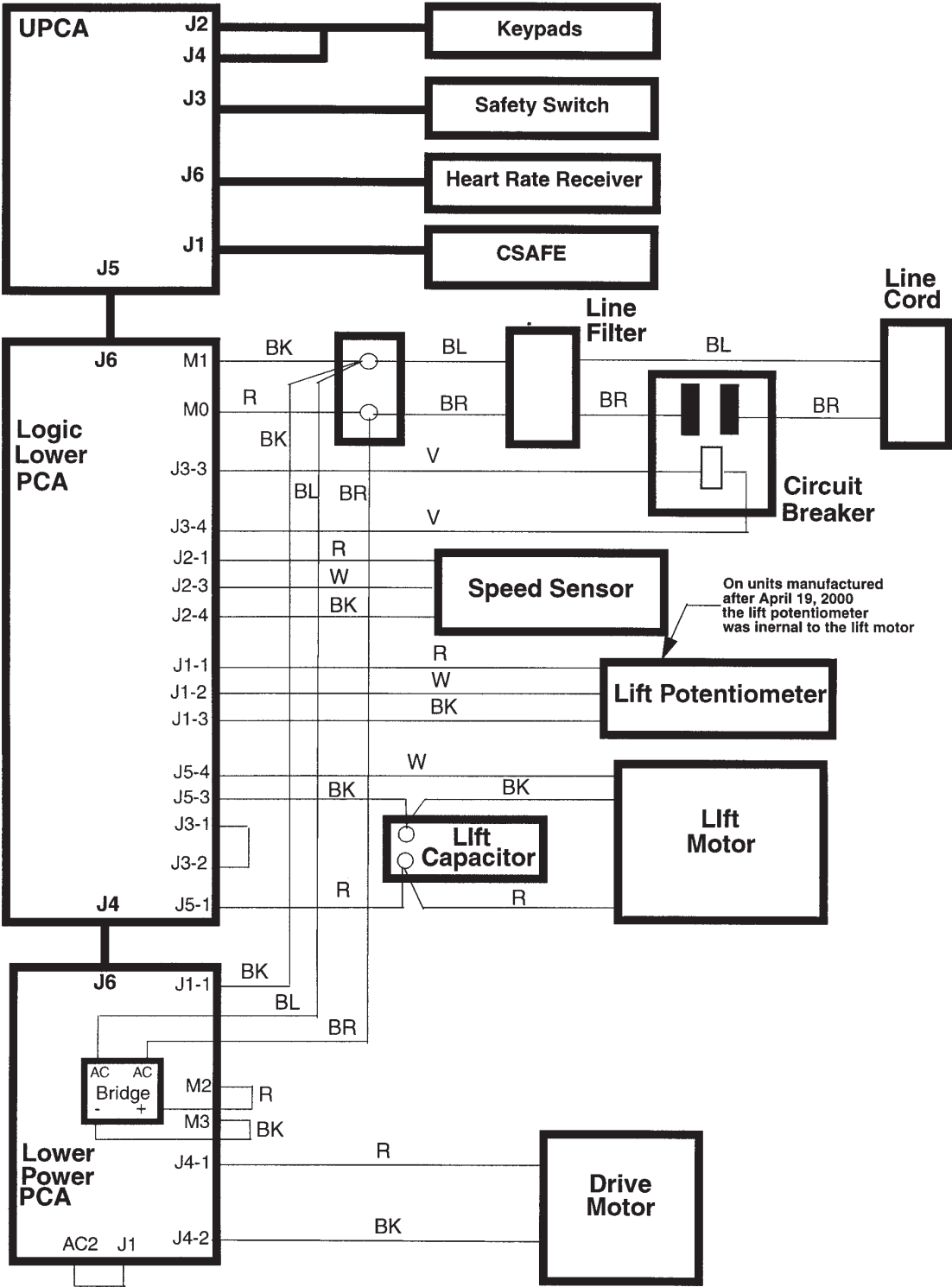

Block Diagram 7.14 - C962i, C964i 120 Vac



C962i120, C964i120 PWM Treadmill

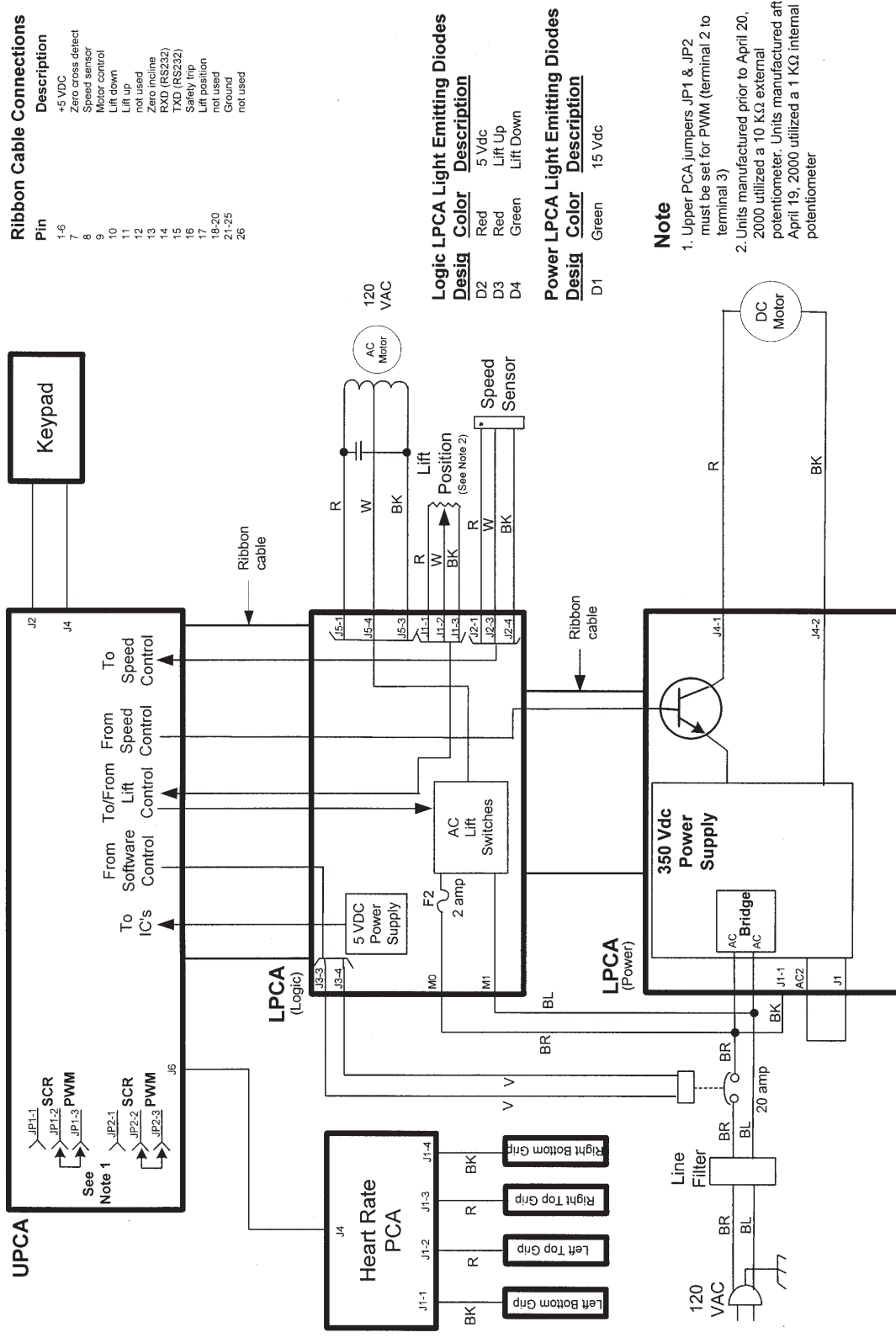

Ribbon Cable Connections

Pin	Description
1-6	+5 VDC
7	Zero cross detect
8	Speed sensor
9	Motor control
10	Lift down
11	Lift up
12	not used
13	Zero incline
14	RXD (RS232)
15	TXD (RS232)
16	Safety trip
17	Lift position
18-20	not used
21-25	Ground
26	not used

Logic LPCA Light Emitting Diodes

Design	Color	Description
D2	Red	5 Vdc
D3	Red	Lift Up
D4	Green	Lift Down

Power LPCA Light Emitting Diodes

Design	Color	Description
D1	Green	15 Vdc

- Note**
- Upper PCA jumpers JP1 & JP2 must be set for PWM (terminal 2 to terminal 3)
 - Units manufactured prior to April 20, 2000 utilized a 10 KΩ external potentiometer. Units manufactured after April 19, 2000 utilized a 1 KΩ internal potentiometer

Wiring Diagram 7.15 - C962i, C964i 240 Vac

